

Overview

WM-DS Series, General Electronics Racks for Small Networking, AV, Telecom & Lab application. Racks manufactured out of steel sheet punched, formed, welded and powder coated with highest quality standards under stringent ISO 9001-2008 Manufacturing & Quality management system to ensure highest quality product.

Standard for Racks configuration will be welded frame integrated with side panel / removable side panel is available and vented top cover with fan mounting provision, Associated Front Glass Door with Lock & Key. Front Section will be hinged to Back section with high quality hinges. Back section will have wall mounting provision. Front & Back section can be Locked with Lock & Key.



Available in 6RU ~ 15RU Variants with 500 & 600 Depth configurations and 550 Width configurations.

Double Section Wall Mount Configurator Drawing with Critical Parts

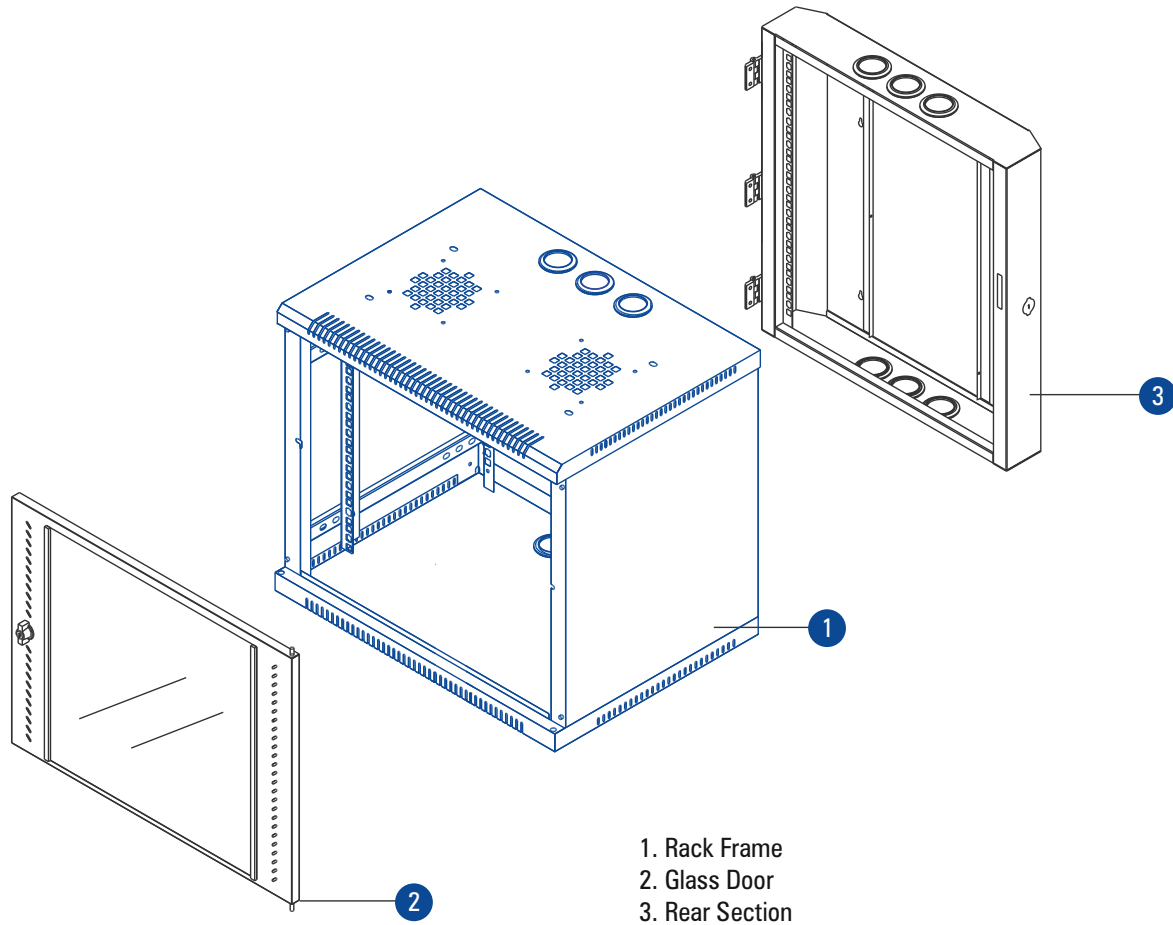

- 1. Rack Frame
- 2. Glass Door
- 3. Rear Section

Features

- Conforms to DIN 41494 or Equivalent EIA /ISO / EN / CEA Standard
- Adjustable mounting depth
- 2 No Adjustable, 19" verticals with Punched 10 mm Square Hole and Universal 12.7mm-15.875mm-15.875mm alternating hole pattern offers greater mounting flexibility, maximizes usable mounting space.
- State-of-the-art manufacturing methods provide the best product quality and fastest delivery in the industry
- 100% assured compatibility with all equipments conforming to DIN 41494 (General industrial standard for equipments)
- Powder coated finish with seven tank pretreatment process meeting ASTM standard
- Grounding & Bonding options
- 1 or 2 Fan Mount provision on top cover

Accessories:

- Cable Organisers
- Power Distribution Units
- Shelves
- Cooling Fans
- Rack ground Kit

Technical Data:

Basic Frame	Steel
Construction	Welded
Top & Bottom Cover	Welded to Frame with Cable entry exit cut outs
Front Door	Lockable Toughened Glass Door
19? Mounting Angle	Formed Steel
Std. Equipment Mounting	DIN Std. 10mm Sq. Slots
Standard Finish	Powder coated
Standard Colour	Grey & Off White OR Black
Rack Standard	Conforms to DIN 41494 or equivalent standard
Static Load	30Kg

Model Matrix & Dimensions

WM-DS Series	H	h	W	w	D	d	D1
6U/550X500	347	6U	550	19?	500	380	100
9U/550X500	481	9U	550	19?	500	380	100
12U/550X500	613	12U	550	19?	500	380	100
15U/550X500	749	15U	550	19?	500	380	100
6U/550X600	347	6U	550	19?	600	480	100
9U/550X600	481	9U	550	19?	600	480	100
12U/550X600	613	12U	550	19?	600	480	100
15U/550X600	749	15U	550	19?	600	480	100

Abbreviations

H - Overall height h - Usable height W - Overall width w - Usable width D - Overall depth d - Usable depth
D1 - Rear Section Depth

